

## Identification of process hazards using thermal analytical techniques <sup>a</sup>

Linda D. Tuma

*Merck, Sharp & Dohme Research Laboratories, P.O. Box 2000, Rahway, NJ 07065 (USA)*

(Received 3 April 1991)

### Abstract

Exothermic decomposition/oxidation and heats of reaction are studied using DTA, DSC, syringe injection calorimetry (SIC) and FAI's reactive system screening tool (RSST) to identify the potential for thermal runaway.

### INTRODUCTION

A critical aspect in the development of any chemical process is the early identification of the potential thermal hazards associated with the process. Once such thermal hazards are identified, the potential risk for thermal runaway can be assessed. Thermal runaway can be initiated in several ways: through an uncontrolled heat of reaction, the initiation of an exothermic decomposition/oxidation, and the combination of these two. It is therefore vital to have information on exothermic decomposition/oxidation and the heat of reaction before any large scale operations are undertaken.

By using DTA, DSC, syringe injection calorimetry (SIC) and FAI's [1] reactive system screening tool (RSST), safety screening can be performed in less than 2 days with a reaction run on a 200 ml scale.

### DETERMINATION OF EXOTHERMIC DECOMPOSITION/OXIDATION

Differential scanning calorimetry (DSC) and differential thermal analysis (DTA) are two thermal techniques which allow for the rapid identification of exothermicity in process samples, while using very small samples. Any of several commercially available thermal analysis systems, including the DuPont 9900 thermal analyzer [2] system with the 910 DSC cell and the standard DTA cell, can be used for this purpose.

DSC and DTA testing can provide information on the size, rate of heat release and initiation temperature of exothermic decomposition/oxidation.

---

<sup>a</sup> Presented at the 19th Annual NATAS Conference, Boston, MA, 23–26 September 1990.

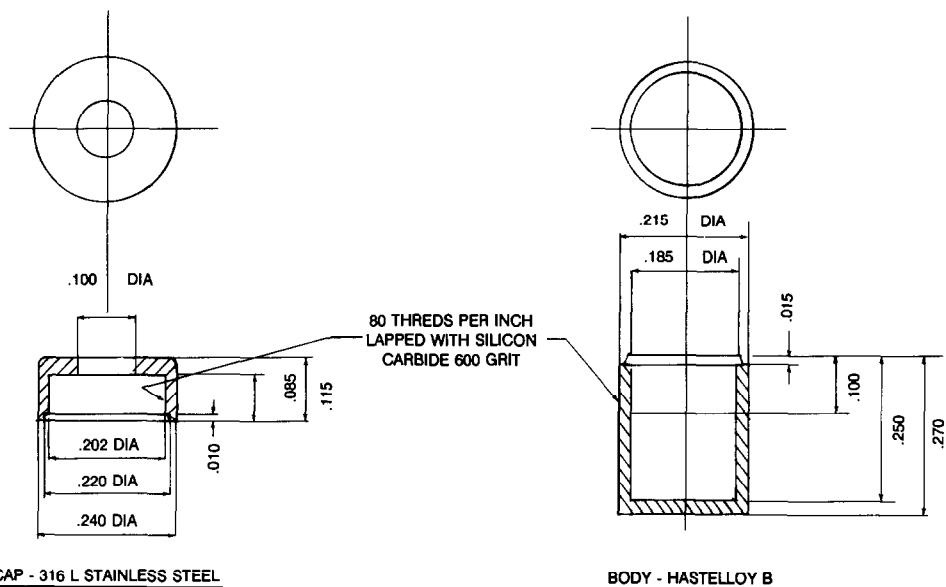


Fig. 1. Sample crucibles.

The use of a specialized DSC sample crucible allows the determination of whether the exotherm is present only in a closed system (pressurized or vacuum system) or present in both the open system (fully vented reaction system) and the closed system.

DSC testing is used to evaluate exothermicity present in a closed reaction system (CB). This is accomplished by the use of a specially designed sample crucible (Fig. 1). The crucibles are constructed of either Hastelloy B or 316L stainless steel to minimize interactions with test samples and have a volume of about 60  $\mu\text{l}$ . These crucibles are reusable, with a screw-on cap which has a replaceable 200 lbf  $\text{in}^{-2}$  "rupture disk" seal. These crucibles allow the evaluation of exothermicity in a closed reaction system without the use of high pressure DSC. Each process sample is normally evaluated for exothermicity behavior from 0 to 300 °C.

DTA scans are used to evaluate the exothermicity of process samples in an open system (OT). A standard 4 mm capillary tube is used to contain the sample. The samples are evaluated from room temperature up to 325 °C. The use of the standard DTA cell, with a silver heating block, allows for evaluation of exothermicity in an open system without use of the DSC open pan sample container. Repeated open pan runs in a DSC cell usually result in corrosion of the cell and a much shortened lifespan for the DSC cell.

Both the DSC and DTA work are performed in an air atmosphere. Whether the exotherm is caused by decomposition or oxidation will be determined at a later time if a potential for thermal runaway is present.

Once the data on exothermicity are evaluated the need for further thermal analysis testing is determined. Additional testing can include isothermal

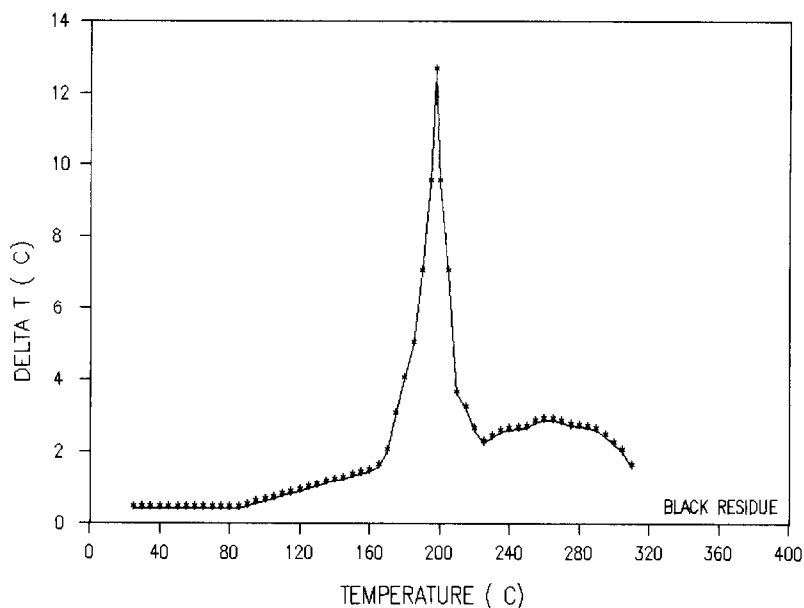


Fig. 2. DTA trace.

DSC studies, adiabatic dewar calorimetry, vent sizing, etc. The following illustrates how standardized DSC and DTA testing are used in conjunction with other test protocols.

During routine thermal analysis screening, a large exotherm, present in both the OT and CB scans (Fig. 2), was found in a reaction mixture. The exotherm initiated at about 80°C, with a heat release of about 110 cal g<sup>-1</sup>. A large percentage of this exotherm was attributable to a polymerization which the sample would undergo at temperatures approaching 100°C, with the remainder attributable to a heat of reaction which had the potential to raise the temperature to the polymerization initiation temperature. The process procedure called for reflux of this sample at 75–85°C for 1 h and then for a 4 h age at 90–95°C.

It was concluded that this exothermic activity was a serious potential hazard and a second stage of thermal analysis was undertaken to fully characterize this exotherm. This included the following:

(1) Drop weight testing. Negative test results indicated that the reaction mixture was not shock sensitive.

(2) Adiabatic dewar studies gave an indication of a slow heat release at temperatures approaching 50°C, accompanied by a  $\Delta T$  of 2–3°C. At temperatures approaching 80°C the rate of heat release was sufficient to push the reaction mass into the exothermic polymerization, with a  $\Delta T$  greater than 200°C.

(3) Contamination studies. Contact with carbon steel resulted in lowering of the exothermic initiation temperature.

(4) VSP testing (vent size determination) indicated a violent and rapid rise in both temperature (more than  $1000^{\circ}\text{C min}^{-1}$ ) and pressure (more than  $50\text{ lbf in}^{-2}\text{ s}^{-1}$ ).

As a result of this additional testing the operating temperature was limited to  $65^{\circ}\text{C}$ . In addition, immediate cooling of the reaction mass if self-heating beyond  $65^{\circ}\text{C}$  was evident as well as the quenching of the batch into water if cooling was insufficient to stop the temperature rise were provided.

## HEATS OF REACTION

An increased focus on safety in the chemical industry has resulted in an increased need for heat of reaction data before scale up. Uncontrolled heats of reaction can result in the vaporization of the solvent present and/or initiation of an exothermic decomposition/oxidation of a process sample, either of which can result in the over pressurization of a process vessel and result in an explosion and/or fire.

The standard methods used to calculate heats of reactions use bond energies, heat of formation and heat of combustion data. Although the calculations are simple, only a limited data base exists, making it difficult to perform the necessary calculations in many instances. Traditional experimental procedures, such as dewar calorimetry and reaction calorimetry, require large amounts of reactants and demand considerable experimental effort. The use of syringe injection calorimetry (SIC) and the reactive system screening tool (RSST) as a calorimeter have been developed to overcome the drawbacks of calculation and other experimental techniques. The SIC and RSST calorimetric techniques provide reasonably accurate data for liquid/liquid and liquid/solid reaction systems.

In SIC, one of the reactants is accurately weighed into the sample crucible and held at room temperature in the DSC cell. After the system reaches equilibrium, a precise amount of the second reactant is rapidly injected into the crucible via a microsyringe. The heat flow is measured versus time and is used to calculate the heat of reaction of the system using the equation

$$\Delta H_{\text{corr}} = \Delta H_{\text{rx}} \times E_{\text{sic}}$$

where  $\Delta H_{\text{corr}}$  is the corrected heat of reaction in kilocalories per mole of the limiting reactant,  $\Delta H_{\text{rx}}$  is the heat of reaction in kilocalories per mole of the limiting reactant as determined from the SIC value for the heat of reaction, and  $E_{\text{sic}}$  is the calibration coefficient for the SIC system.

This technique is applicable to systems where the reaction takes place rapidly at room temperature, the reaction is not affected by air or moisture, the reactants mix readily, the mixture is homogeneous after the reaction is complete and where there is negligible gas generation during the reaction. For reactions which meet these requirements, the technique provides a rapid and accurate method for measuring heat of reaction data.

With the RSST calorimetric system, one reactant is accurately weighed into the 10 ml reactor flask and is held at room temperature. The heater system is left off and the RSST unit itself is left unpressurized. After the system reaches thermal equilibrium, an accurately weighed sample of the second reactant is rapidly injected into the reactor flask via syringe. The RSST computer system will record both the temperature change and the rate of temperature change ( $dT/dt$ ). The RSST computer system also has the capability to reduce this data ( $\Delta T$  and  $dT/dt$ ), creating a file from which data can be plotted. From the plots of this data, or the reduced data printout,  $\Delta H_{rx}$  for the reaction can be determined using the equation

$$\Delta H_{rx} = \frac{m_1 \times H_{cap} \times \Delta T}{[LR_m/LR_{mw}] \times 1000}$$

where  $\Delta H_{rx}$  is the heat of reaction in kilocalories per mole of limiting reactant as determined from the measured  $\Delta T$ ,  $m_1$  is the total mass in grams for both reactants in the reaction system,  $H_{cap}$  is the heat capacity for the reaction system in  $\text{cal g}^{-1} \text{deg}^{-1}$ ,  $\Delta T$  is the temperature rise ( $^{\circ}\text{C}$ ) that accompanies the reaction as determined from the reaction run in the RSST unit,  $LR_m$  is the actual mass of the limiting reactant in grams, and  $LR_{mw}$  is the molecular weight of the limiting reactant in  $\text{g (g mol)}^{-1}$ .

The plot of the log  $dT/dt$  versus  $1/1000 T$  ( $T$  in kelvin) permits the determination of the maximum rate of temperature rise that takes place during the reaction. This parameter is useful in assessing the rate of reaction and whether one or more reactions are occurring simultaneously.

The RSST calorimetric technique is applicable where the reaction takes place at room temperature in less than 5 minutes and there is negligible gas generation. Mixing or reaction with air/moisture is not a problem, as it is with the SIC technique, as the RSST has stirring and nitrogen purge capabilities. Two areas of concern are currently being addressed: (1) the ability to run reactions at elevated temperatures, by FAI [1] who are developing a program for the RSST unit which will allow heating of a reaction mass to a specified temperature and the ability to maintain that temperature; and (2) the ability to measure the heat released during a very slow reaction, by the Operational Hazards Laboratory at Merck which is evaluating the use of a small dewar flask in place of the thin-walled glass vessel currently used in determining heats of reaction with the RSST unit.

SIC and RSST are capable of providing accurate, rapid and reproducible results for heats of reaction. A typical reaction can be studied by both techniques in less than 4 h using milliliter and milligram quantities of reactants. Under the best of conditions, the heat of reaction determined using these techniques is within  $\pm 5\%$  of the theoretical value. In cases where these techniques are inappropriate or incapable of providing the heat of reaction data or where additional information is needed, use of reaction calorimeter or dewar calorimetry is recommended.

TABLE 1

Results of heat of reaction studies for various systems

Reaction number	Reaction type	Heat of reaction (kcal mol <sup>-1</sup> )			Maximum temp rise (deg min <sup>-1</sup> )
		SIC	RSST	Calculated	
1	Ring closure <sup>a</sup>	-2.5	-2.6	-	55
2	Silylation <sup>b</sup>	-7.1	-7.3	-	4
3	Triethyl amine + HCl	-17.8	-19.7	-	2296
4	Methanol + diisobutyl aluminum hydride	-28.1	-26.3	-	499
5	Acylation <sup>c</sup>	-22.5	-19.7	-	60
6	Alcohol formation <sup>d</sup>	-	-23.2	-	535, 44 <sup>d</sup>
7	Acylation <sup>e</sup>	-60.0	-59.9	-	516
8	Acylation <sup>f</sup>	-63.1	-56.5	-	902
9	Vitride <sup>g</sup> + water	-59.2	-64.9	-	470
10	Rochelle salts <sup>h</sup> + diisobutyl aluminum hydride	-65.0	-70.6	-	22
11	Sodium cyanide + sodium hypochlorite	-101.0	-92.0	-88.6	803
12	Hydrogen peroxide + sodium sulfite	-82.4	-103.6	-90.3	3105

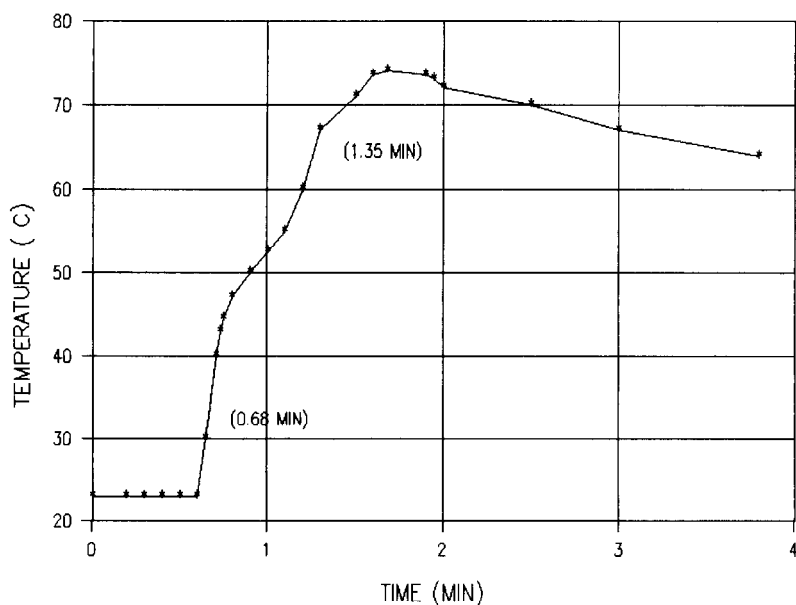
<sup>a</sup> Trifluoroacetic anhydride + proprietary compound.<sup>b</sup> Imidazole + *t*-butyldimethylsilyl chloride.<sup>c</sup> Acetic anhydride + proprietary compound.<sup>d</sup> Two step reaction (see Fig. 4).<sup>e</sup> Trifluoroacetic anhydride + proprietary compound.<sup>f</sup> Butryl chloride + proprietary compound.<sup>g</sup> (Na bis[2-methoxyethoxy]aluminum hydride).<sup>h</sup> Sodium potassium tartrate.

Fig. 3. RSST data plot (temperature vs. time).

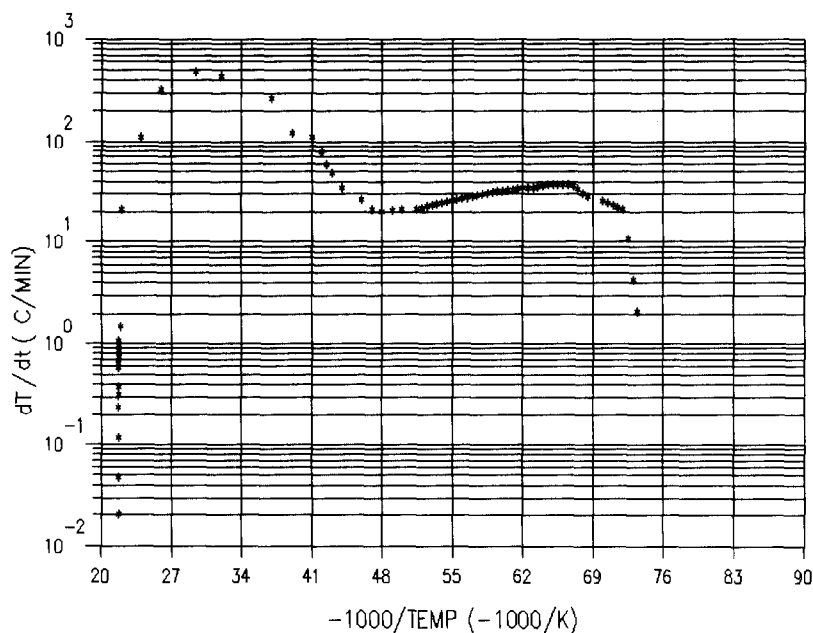


Fig. 4. RSST data plot ( $dT/dt$  vs.  $-1000/T$ ).

Table 1 contains the results of twelve heat of reaction studies, including the results from SIC, RSST and, in several instances, the calculated values. As can be seen, the heat of reaction and the rate of reaction, as inferred

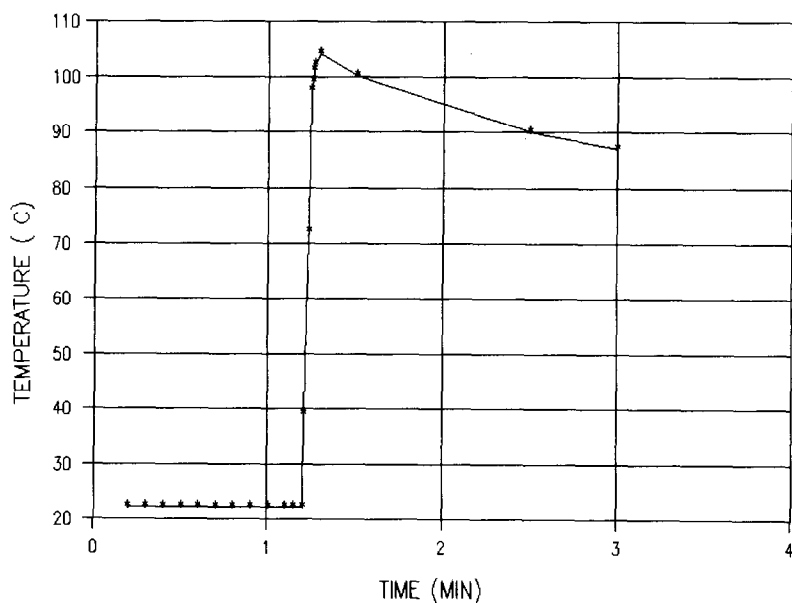


Fig. 5. RSST data plot (temperature vs. time).

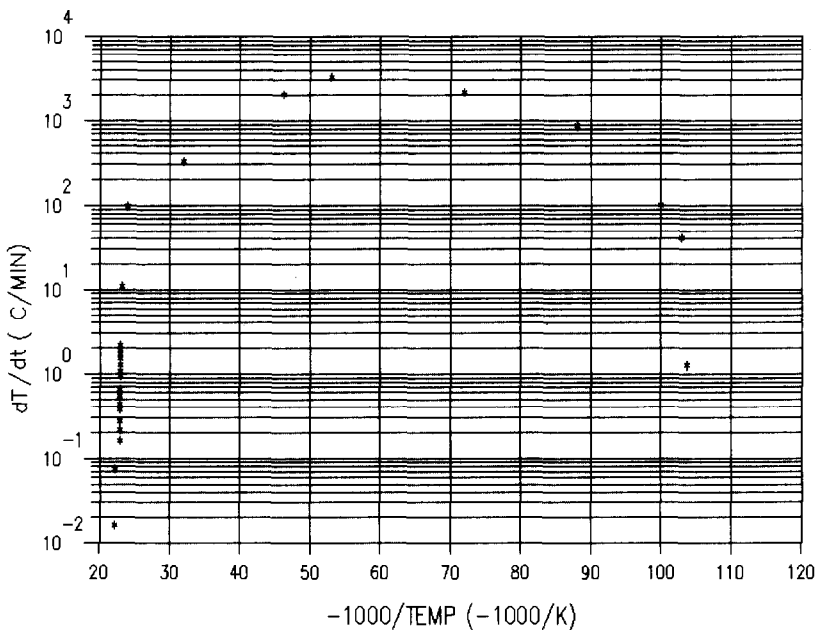


Fig. 6. RSST data plot ( $dT/dt$  vs.  $-1000/T$ ).

from the maximum temperature rise rate, are quite varied. Reaction 6 from Table 1 is a reaction between an alcohol and a ketone. The RSST data indicate that this is a two step reaction, with the second step being the rate-controlling step (Figs. 3 and 4). Reaction 12 is the reaction of hydrogen peroxide and sodium sulfite. The RSST results (Figs. 5 and 6) indicate a one step, instantaneous reaction with a maximum rate of temperature rise of over  $3100^\circ\text{C min}^{-1}$ . Hydrogen peroxide was used as an oxidant in this reaction, with the excess being destroyed with sodium sulfite after the reaction was complete. It was critical to ensure that the reaction had taken place before the addition of the sodium sulfite, as a violent reaction would occur if there were large amounts of unreacted peroxides present.

## CONCLUSIONS

DSC, DTA, SIC and RSST are capable of providing reliable data on exothermic decomposition/oxidation and heats of reaction. The evaluation of these data identifies the potential for thermal runaway. Additional thermal testing may be necessary in some cases to accurately determine the conditions under which thermal runaway will be encountered.

## REFERENCES

- 1 Fauske and Associates, Inc., 16W070 West 83rd Street, Burr Ridge, IL, USA.
- 2 E.I. Dupont, Instrument Systems, Concord Plaza, Wilmington, DE, USA.